



---

Advanced Radio Modules

---

Modem Radio Digital

**ARM-DXXXX**

---

User Guide



Concerned model:  
ARM/868-DXXXX



ATIM Radiocommunications  
Chemin des Guillets  
38250 Villard de Lans  
France

[www.atim.com](http://www.atim.com)  
[info@atim.com](mailto:info@atim.com)

## TABLE OF CONTENTS

Document version history.....	3
Disclaimer.....	3
Trademarks and copyright .....	3
Declaration of compliance .....	4
Environmental recommendations .....	4
Explosive atmosphere .....	4
Environment.....	4
Radio	5
Versions.....	5
1. Operating mode.....	6
1. ARM/XXX-D General characteristics .....	6
1. Technical characteristics ARM/XXX-D .....	6
2. Installation.....	8
2.1 Antenna.....	9
2.1.1 Mounting on a cabinet .....	10
2.1.2 Outside mounting of the antenna (on mast).....	10
2.1.3 Spectrum .....	11
2.1.4 Distance of transmission.....	11
2.1.5 Radio channel selection.....	11
2.2 ARMD modem connections.....	12
2.2.1 Power Supply .....	14
2.2.2 RS485 serial link.....	15
2.2.3 Digital input .....	15
2.2.4 Digital output.....	16
2.2.5 Girl card digital input.....	16
2.2.6 Girl card digital input.....	16
2.2.7 Girl card analogic input .....	16
2.2.8 Girl card analogic output.....	17
3. Update and setup .....	18
3.1 Radio modem update and setup .....	18
3.2 Modem update .....	18
3.3 Setup through the configurator.....	20
Mode Advanced.....	22
4. Operating mode.....	23

4.1	Inputs-Outputs Modbus mode access .....	23
	Remarks .....	30
4.2	Inputs-Outputs Mirror mode access.....	31
4.3	<b>Repeater function</b> .....	33
4.4	Watchdog alarm .....	33
4.5	Standby mode.....	33
4.6	SIGFOX mode .....	34
	<b>Mode of detection on change of state of the logical inputs:</b> .....	34
	Remark.....	36
	<b>ACCESS TO DATA ON ATIM PLATFORM</b> .....	37
4.7	Mode LORAWAN.....	37
5	Test Mode.....	42
6	Maintenance.....	43
7	Troubleshooting.....	49
	<b>The modem cannot be configured</b> .....	49
	<b>Radio data not received</b> .....	49
8	Technical support .....	49

## Document version history

Version	Date	Description	Author
1.0	01/11/2015	Document creation	TL
1.4	01/04/2016	Girl card	TL
1.5	19/04/2016	Document format	TL
1.6	07/11/2017	Update	YL
1.7	06/05/2019	Sigfox mode	TL
1.8	09/05/2019	Multiple mirror mode 1	TL
1.9	27/06/2019	Multiple mirror mode 2	TL
1.10	07/10/2019	Daughter board	TL
1.11	19/11/2019	LoRaWAN mode	TL
2.00	11/05/2023	Mise à jour Nouvelle Version	TL
2.00	16/05/2023	Mise à jour	TL

## Disclaimer

The information contained in this document is subject to change without warning and does not represent a commitment on the part of ATIM radiocommunications. ATIM radiocommunications provides this document 'as-is' with no warranty of any kind, express or implied, including but not limited to implied warranties of merchantability or fitness for a particular purpose. ATIM radiocommunications may make changes and/or improvements to this manual or to the product(s) or program(s) described in this manual, at any time.

## Trademarks and copyright

ATIM radiocommunications®, ACW ATIM Cloud Wireless® and ARM Advanced Radio Modem® are registered trademarks of ATIM SARL in France. The other trademarks mentioned in this document are the property of their respective owners.

## Declaration of compliance

All ACW Atim Cloud Wireless® products comply with the regulatory requirements of the R&TTE Directive (2014/53/EU), article 3:



### 1 SAFETY (Article 3.1a of the 2014/53/EU Directive)

NF EN60950-1 Ed. 2006/A1:2010/A11:2009/A12:2011

(health) EN62479: 2010 (power <20mW) or EN62311:2008

(power > 20mW)

### 2 Electromagnetic compatibility (Article 3.1b of the

2014/53/EU Directive) EN 301489-3 v1.4.1, EN 301489-1 V1.9.2

### 3 Efficient use of the radio frequency spectrum (Art.3.2 of the 2014/53/EU

Directive) ETSI EN300 220-2 v2.4.1 and EN300 220-1 v2.4.1

## Environmental recommendations

### Explosive atmosphere

Except for the ACW-ATEX line specifically intended for this purpose, do not use ACW radio modems in the presence of flammable gases or fumes. Using the equipment in such an environment constitutes a safety hazard.



The ACW-MR2-Ex complies with the standards EN 60079-0 and EN 60079-11 ("ic").

ACW-MR2-Ex can be used in an explosive atmosphere, Zone 2, gas group IIB, T4 temperature classification for a maximum ambient temperature of 55 °C.

Corresponding ATEX certification is  II 3 G, Ex ic IIB T4 Gc.



The ATEX certification of this ACW-MR2-EX product is only valid with the SATE LS14500EX ATEX Certified Reference Battery.

Using another type of battery can cause an explosion. The housing must be screwed to the equipment ground via the supplied bracket or a ground wire screwed to the equipment (not supplied). ATIM disclaims any liability for failure to comply with these procedures

### Environment

Respect the temperature ranges for storage and operation of all products. Failing to respect these guidelines could disrupt device operation or damage the equipment. ACW products in IP65 water- and dust-resistant housings may be placed outdoors, but must not, under any circumstances, be submerged.

Follow the instructions and warnings provided below to ensure your own safety and that of the environment and to protect your device from any potential damage.



**General hazard** – Failure to follow the instructions presents a risk of equipment damage.



**Electrical hazard** – Failure to follow the instructions presents a risk of electrocution and physical injury.



Direct-current symbol



**WARNING:** do not install this equipment near any source of heat or any source of humidity.



**WARNING:** for your safety, it is essential that this equipment be switched off and disconnected from mains power before carrying out any technical operation on it.



**WARNING:** the safe operation of this product is ensured only when it is operated in accordance with its intended use. Maintenance may only be performed by qualified personnel.



Waste disposal by users in private households within the European Union. This symbol appears on a product or its packaging to indicate that the product may not be discarded with another household waste. Rather, it is your responsibility to dispose of this product by bringing it to a designated collection point for the recycling of electrical and electronic devices. Collection and recycling waste separately at the time you dispose of it helps to conserve natural resources and ensure a recycling process that respects human health and the environment.



For more information on the recycling center closest to your home, contact your closest local government office, your local waste management service or the business from which you purchased the product.

## Radio

Modems in the ARM line are radio-communication modems that use the ISM (industrial, scientific and medical) bands, which may be used freely (at no cost and with no authorization required) for industrial, scientific and medical applications.

## Versions

- ARM/868-D-2200: Frequency: 865-870Mhz 2 digital inputs (dry contacts) and 2 digital outputs (dry contacts)
- Radio cards:  
868MHz / 500mW: ARM-N8LD

## 1. Operating mode

The ARM / 868-D modem is used for the transfer of digital or analog input outputs.

While very easy to use, the ARM / 868-D is fully configurable by specific software via the USB connector.

### 1. ARM/XXX-D General characteristics

- Logic and Analog Output Input
- 2 digital inputs
- 2 digital outputs
- 1 Alarm output
- Half Duplex Radio Transfers
- Frequency 868Mhz (ARM-N8LD Radio Card)
- Default 19200bps radio speed (Possibility 9600bps or other depending on radio card) Radio power; 5 ... 25 ... 500mW (868Mhz)
- Operation Mode : MODBUS , MIROR
- Configuration by USB

### 1. Technical characteristics ARM/XXX-D

Radio module ARM-N8 (Document: USER GUIDE ARM N8LD-LP)

- Frequency Band: 863-870Mhz
- ARM Compatibility: 868-870Mhz
- Bitrate: 1200bps to 57600bps
- ARM Compatibility: 19200bps / 9600bps
- Number of channels: 560
- ARM Compatibility Number of Channels 15
- Modulation Type: FSK, 2GFSK, 4GFSK Stability Frequency: + - 1kHz
- Power: 5mw to 500mW
- Receive sensitivity: -123dBm (1200bps),: -116dBm (19200bps)
- Adjacent channel selectivity: -41Bm to 19K2
- Certified EN 300 220 V2.4.1
- SMA antenna connector

## Modem ARM/xxx-D

- Opto-Isolated Positive Logic Input:
- MOS Positive Logic Output
- Alarm Output: MOS Positive Logic Output
- Analog Input 0-20mA 12bits (Option)
- Analog output 0-20mA 12bits (Option)
- USB programming interface
- Power supply: + 10V to + 30Vdc
- Max consumption: 60mA (reception) 500mA (emission)
- Operating temperature: -20 ° C / + 55 ° C
- Aluminum housing: 105 \* 80 \* 31 mm (Off Antenna)
- Weight 250g

## ARM/xxx-D modem delays

- Modem wakeup time after power on minimum 500ms
- Typical Times ModBus Response: <100ms (ARMSE Modem Serial Link Measurement)
- Mirror cycle time: Minimum: 500ms

## LEDs meaning

- LED "ON": Indicates the operation of the modem
- LED "S1": Indicates the state of the output 1
- LED "S2": Indicates the status of output 2
- LED "S3": Indicates the status of the alarm output
- LED "E1": Indicates the state of the input 1
- LED "E2": Indicates the state of the input 2
- "Tx" LED: Indicates a current radio program
- "Rx" LED: Indicates a radio reception in progress



## 2. Installation

During installation please observe the following instructions:



**WARNING:** the power supply of the equipment must be connected to an electrical installation complying with the standardization in force in the country (NFC 15-100 in France). It must be equipped with protections against overcurrent, overvoltages, earth faults (maximum 16A rating).



**WARNING:** All equipment connected to the product must conform to EN 60950-1 Ed. 2006 or their product standard.



**WARNING:** The power supply of the equipment must have a disconnecting device in accordance with IEC 60947. The disconnecting device must be as close as possible to the power supply and must cut off all active poles.



**WARNING:** Do not install the equipment near or near a source of heat.



**WARNING:** for your safety, it is imperative that before any technical intervention on the equipment it be turned off and not connected to the mains.



**WARNING:** the security provided by this product is only ensured for a use in accordance with its purpose. Use only the recommended power supply ALIM220-24V-1A or a power supply in accordance with EN60950-1: 2006, limited power.



**WARNING:** the safety provided by this product is only ensured for a use that corresponds to its purpose. Maintenance can only be performed by qualified personnel.



**WARNING:** Do not use the radio box directly outdoors, it is not waterproof and is intended to be integrated in a box or in an electrical cabinet (optional on request).



**WARNING:** Connect the Din Rail bracket to ground so that the radio box is grounded. If an external mast antenna is used, it must also be connected to earth and possibly add a surge arrester (see diagram below)



**WARNING:** Observe the standards using only the cables and antennas recommended, so as not to exceed the effective radiated power (P.A.R.) allowed.

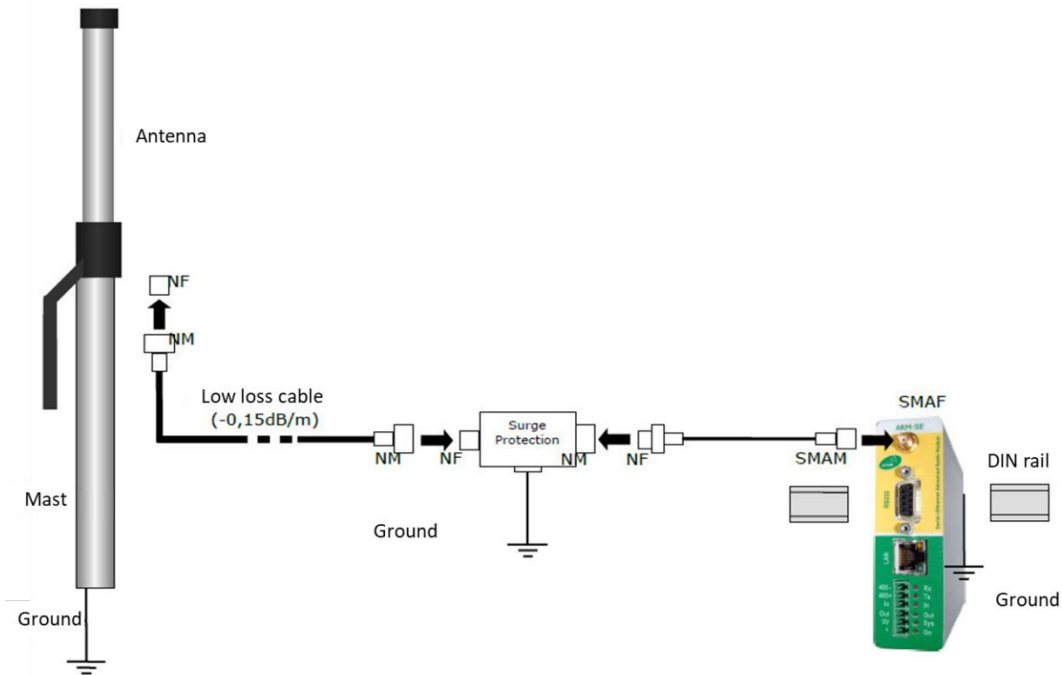





**Figure 1: Connecting the antenna.**  
 The use of coaxial cable type RG58 (-1dB / m) is not recommended (high loss)

## 2.1 Antenna

A bad choice of antenna can have considerable consequences on the quality of the radio link. It is important to use a suitable antenna and, if necessary, a low loss cable to place it in a slightly obstructed area.

Table 1 shows the antennas available to order:

ANT868-14S-L		1/4 "roof antenna with 3m80 cable + SMAM plug (Length 0.5, 1 or 3m80)
ANT868-12FSC		Whip Antenna 1/2 SMA angled wave (direct mounting on A.R.M.)
ANT868-12S-L		Whip Antenna 1/2 SMA angled wave (direct mounting on A.R.M.)
ANT868-BZ		Omni-directional antenna "Bazooka" 4.15dBi for mast mounting (with mounting flange) N-plug female
ANT868-Y12		Yagi 6-element 12 dBi directional antenna, female N-connector (Be careful to respect the standards in force!)

### 2.1.1 Mounting on a cabinet

A.R.M. radio modems can be supplied with a  $\frac{1}{2}$  wave whip antenna angled so that the antenna is positioned vertically directly on the modem.

This antenna is interesting if A.R.M. is mounted in a plastic box. In this case the antenna must not be placed against a metal plate (bottom plate for example).  $\frac{1}{2}$  Wave antennas do not require a ground plane and can therefore be mounted directly on a non-metallic surface.

If the radio modem is mounted in a cabinet or metal cabinet, you can use the antenna ANT868-14S, antenna  $\frac{1}{4}$  roof wave with its cable and SMA plug.

The antenna should be mounted vertically (up or down, depending on the area to be watered). For optimal results, it is advisable to place it high and clear of any metallic obstacle in a radius of 1 meter if possible (see figure 2).

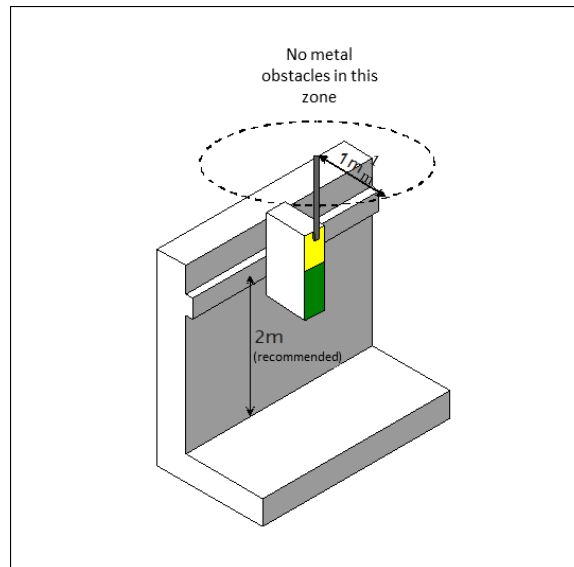
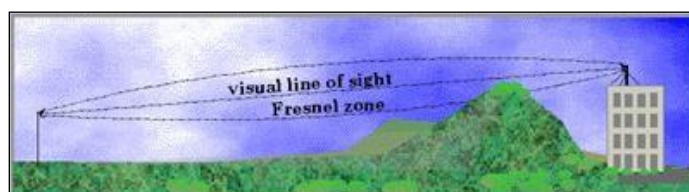

**Figure 2: Placement of the modem.**

### 2.1.2 Outside mounting of the antenna (on mast)

In this case, you can use the antenna referenced ANT868-BZ with a cable type CFP10 (low loss diameter 10mm). With this type of cable, you can deport the antenna 10 or 20m or more depending on the link budget (we can calculate it for you to know the distance between the two or more points, the type of antenna and the desired cable length). Do not use any coaxial cable or RG58 which, at this frequency, causes a colossal loss. See Table 1 previously.

There is in radio what one calls "the area of Fresnel" which makes an ellipse between the 2 antennas (see figure 3). The more we wish to transmit far, the more it will mount antennas ( $\sim 1\text{m} / \text{km}$ , a height of 5m for 5kms), this to avoid any obstacle in this area. In free field and at sight, with antennas installed according to these recommendations, the range of A.R.M radio modems can go up to several km.



**Figure 4: Fresnel's zone.**

### 2.1.3 Spectrum

Before installation, check if possible which radio frequencies are used nearby.

### 2.1.4 Distance of transmission

The ARM / 868-D version extends the range to more than 10kms.

### 2.1.5 Radio channel selection

The selection of the radio channel is done either by the USB configurator or by the encoder wheel. It is possible to use the other radio channels of the radio module other than those of the coding wheel. To do this you have to deactivate the checkbox of the configurator (Coding Wheel channel enable).

The encoder wheel has 16 positions from 0 to F (hexadecimal). Position 0 is used for updating the software. There are 2 corresponding tables for one at frequencies compatible with the old range and for the other at 15 frequencies compatible with the new range ARM-N8. This selection is made using the checkbox "Compatibility ARM".

The configuration of the modem must comply with the standard and therefore, the parameterization must respect a transmission time (duty cycle). The power is not the same depending on the chosen channel, see below:

Compatible ARM Frequency Table

Channel	Frequency (MHz)
0	Do not use
1	868.075
2	868.125
3	868.175
4	868.225
5	868.275
6	868.325
7	868.375

Channel	Frequency (MHz)
8	868.425
9	868.475
A	868.525
B	869.850
C	869.900
D	869.475
E	869.525
F	869.575

Max.ERP: 25mW Duty cycle: 1%
Max. ERP: 5mW Duty cycle: 100%
Max.ERP: 500mW Duty cycle: 10%

ARM-N8 frequency table

Channel	Frequency (MHz)
0	Do not use
1	867.850 (388)
2	867.925 (394)
3	868.000 (400)
4	868.075 (406)
5	868.150 (412)
6	868.225 (418)
7	868.300 (424)

Channel	Frequency (MHz)
8	868.375 (430)
9	868.450 (436)
A	868.6 (448)
B	869.8 (544)
C	869.925 (554)
D	869.45 (516)
E	869.525 (522)
F	869.6 (528)

Max. ERP: 25mW Duty cycle: 1%
Max. ERP: 5mW Duty cycle: 100%
Max. ERP: 500mW Duty cycle: 10%

For other frequencies, see the table in the manual: USER GUIDE ARM N8LD-LP

2.2 ARMD modem connections

Pin 10	Do not use
Pin 9	Do not use
Pin 8	Digital input 1
Pin 7	Digital input 2
Pin 6	0V Power supply
Pin 5	Digital output 1
Pin 4	Digital output 2
Pin 3	Alarm digital output
Pin 2	0V Power supply
Pin 1	+ 10/30vcc Power supply

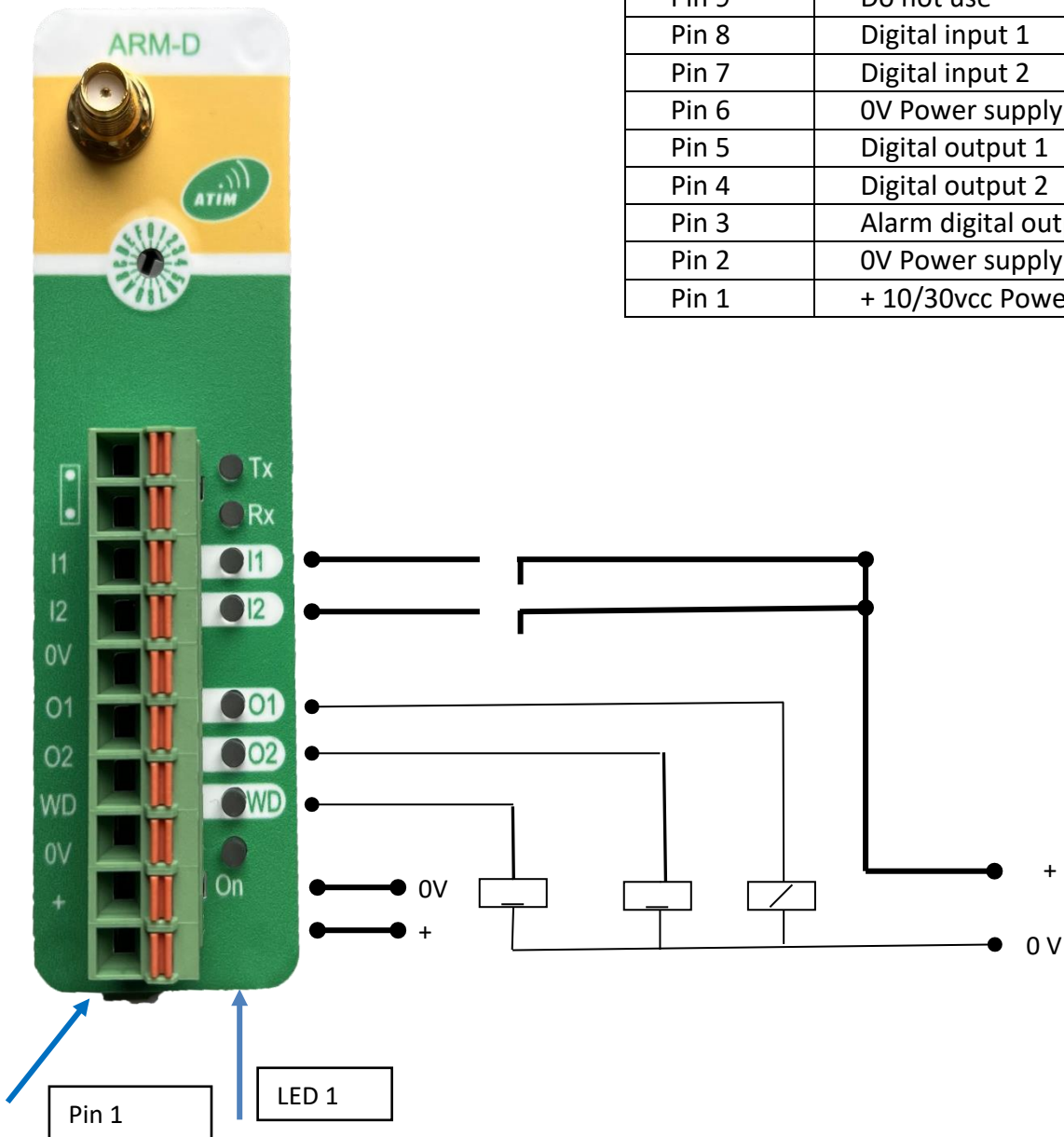

LED 8	Green	Tx: Emission
LED 7	Green/Red	Rx: Reception/Error
LED 6	Yellow	I1: Digital input 1
LED 5	Yellow	I2: Digital input 2
LED 4	Red	O1: Digital output 1
LED 3	Red	O2: Digital output 2
LED 2	Red	WD: Alarm digital output
LED 1	Green	ON: Power supply

### Connection card girl input additional output

Up to four daughter cards can be added to the modem. These daughter cards are not removable, the configuration must be defined when ordering.

Several types of girl cards are available:

- Logic input
- Logic output
- Analog input
- Analog Output

The RS485 link is always wired with the daughter cards. The RS485 link is used in MODBUS mode for wired other slaves and in MIRROR mode for the addition of input output (See option with ATIM).

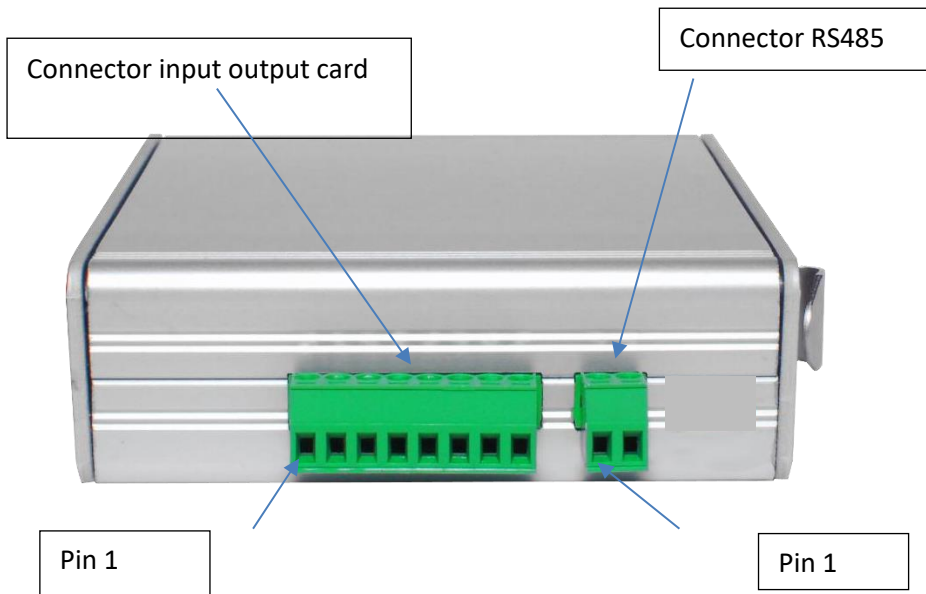

Pin 1	Input Output Card 1
Pin 2	0V
Pin 3	Input Output Card 2
Pin 4	0V
Pin 5	Input Output Card 3
Pin 6	0V
Pin 7	Input Output Card 4
Pin 8	0V

Pin 1	RS485+
Pin 2	RS485-

## 2.2.1 Power Supply

Connect your power supply between the 0V and + terminals of the removable terminal block.

This must be between 10 and 30V and rectified, filtered. Beware of 220V power supply units that are often of poor quality and can deliver peaks below 9V!

We recommend the use of our 24V reference ATIM power supply: ALIM220-24V-1A

The power supply must be near the radio modem.

The cable for the power supply must be 3 conductors of section 0.5 (blue, brown, green / yellow) and maximum length 3m.

The power cable for the ARM radio modem must be 2 conductors of section 0.5 (black and red color) and maximum length 3m.

Reverse polarity protection. Surge protection

Consumption:

- Reception : 60mA
- Emission (Max value) 500mW : 500mA

### Safety instructions for our power supply **ALIM220-24V-1A**

- Before proceeding with the installation, read these instructions carefully and completely.
- Aliment These power supplies have been built in accordance with the safety instructions IEC / EN60950-1, UL60950-1 and UL508. They are approved / certified (BG mark) in accordance with EN60950-1, EN50178, EN61558-2-8 and meet the requirements of the Low Voltage Directive (LVD). They are UL and cUL Listed to UL 60950-1 and UL 508 (listed).
- Before installing, servicing or modifying the unit, switch off the main switch on the device and make sure it can not be turned back on. When the device is running, some parts are subject to dangerous voltage. Improper handling of the device can lead to death, serious injury, or serious property damage. The proper operation and safety of the device depend on proper storage, assembly and installation.
- The installation of the device requires that the relevant national regulations (in the USA, Europe and other countries) that apply to this product must be observed. Before commissioning the device, please observe the following conditions:
  - The supply connection must be made in accordance with national standards (VDE0100 and EN50178).
  - If you use twisted wires, you must secure them in the clamps.
  - Provide a suitable isolation device to isolate the device from the power supply circuit.
  - Degree of protection I to IEC536. Any ground contact must be connected to terminal FG (protection class I).
  - All lead wires must be designed for the output current and must be connected to the correct polarity.
  - Ensure sufficient cooling.
- **Never perform any work while the device is running!** Risk of electric shock and electric arcing that can lead to death, serious injury or substantial property damage.
- Caution: Dangerous voltages and components containing a very large quantity of electrostatic elements are present in this power supply during normal operating conditions. Those are inaccessible. Improper handling can cause electric shock or serious burns! **Do not open the power supply until at least 5 minutes after it has been disconnected from the power supply at all poles.**
  - Only qualified personnel can open the device!

- Do not put objects into the device. The output voltage adjustment potentiometer can only be operated with an insulated screwdriver.
- Do not expose the unit to fire or water.

#### Installation instructions

- This power supply is designed for professional indoor systems. During operation the power supply must be inaccessible. It can only be installed and put into operation by qualified personnel.
- Does not work without PE connection! In order to comply with the safety instructions and EMC (CE mark, certifications), the power supply can only be put into operation if the PE terminal is connected to the non-integrated earth conductor.
- The correct mounting position for optimum cooling must be observed. Do not cover the ventilation holes. A space of at least 50 mm above and below the unit must be left in order not to hinder natural convection. Watch for power reduction.
- The internal fuse is not accessible. As such it cannot be replaced by the user. If the internal fuse blows, the power supply has an internal fault and for safety reasons must be transferred to the local distributor. If the internal fuse needs to be replaced in the field, replace it with a fuse of the same type and power for continuous protection against any risk of fire.
- **Recycling:** The unit contains items that are designed for recycling, and components that require a special deposit. You are therefore requested to ensure that the device will be recycled at the end of its commissioning.

#### 2.2.2 RS485 serial link

Option added with the addition of additional daughter cards

The configuration is done by the ARM-D Configurator

#### 2.2.3 Digital input

- Number 2 version ARM-D-2200
- Type: Positive Logic
- High state voltage range: 4V to 30V
- Maximum voltage low: 0V to 3.9V
- Material filtering: 2500Hz
- Software Filtering: 10Hz
- Consumption: 2.3mA (9V); 3mA (12V); 7.5mA (24V); 12mA (30V)
- Counting on each input (maximum counting frequency 10Hz)



#### 2.2.4 Digital output

- Number 2 version ARM-D-2200
- Type: MOSFET (Positive Logic)
- Voltage Range: 9 to 30Vdc
- Maximum charging current: 0.5mA
- Short circuit protection: 0.7A to 1.5A
- Leakage current: 100µA

#### 2.2.5 Girl card digital input

- Number 1
- Type: Positive Logic
- High state voltage range: 6V to 30V
- Maximum voltage low: 0V to 5V
- Material filtering: 2500Hz
- Software Filtering: 10Hz Consumption: 3mA (9V); 5mA (12V); 10mA (24V); 13mA (30V)
- Counting on each input (maximum counting frequency 10Hz)

#### 2.2.6 Girl card digital input

- Number 1
- Type: MOSFET (Positive Logic)
- Voltage Range: 9 to 30Vdc
- Maximum charging current: 0.5mA
- Short circuit protection: 0.7A to 1.5A
- Leakage current: 100µA

#### 2.2.7 Girl card analogic input

- Number: 1
- Type: 0-20mA
- Resolution: 12bits (4095pts)
- Material Filtering: 500Hz
- Input impedance: 100 Ohm
- Maximum error: 0.5% PE
- Allowable overvoltage: 5V

### 2.2.8 Girl card analogic output

- Number: 1
- Type: 0-20mA
- Resolution: 12bits (4095pts)
- Maximum error: 0.5% PE
- Power loop through the modem power

### 3. Update and setup

#### 3.1 Radio modem update and setup

The update and configuration of the modem is done using a USB cable (mini USB PC cable) The USB connector is on the back of the modem.

#### 3.2 Modem update

Download on the ATIM website the update software: USB Bootloader. Download the program file: ARMD Vx.x

On the modem put the wheel the encoder wheel on the 0 position Connect the USB cable

Powering

LED 1 Power LED (Green LED) flashes

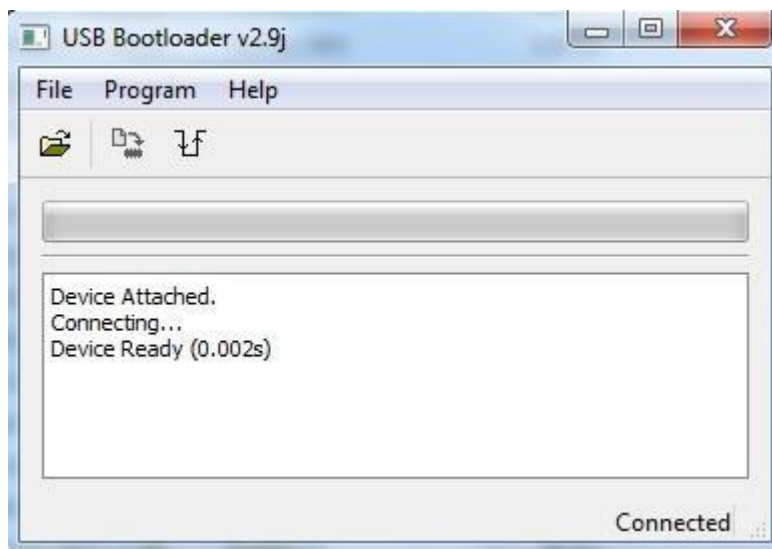

Open the program file

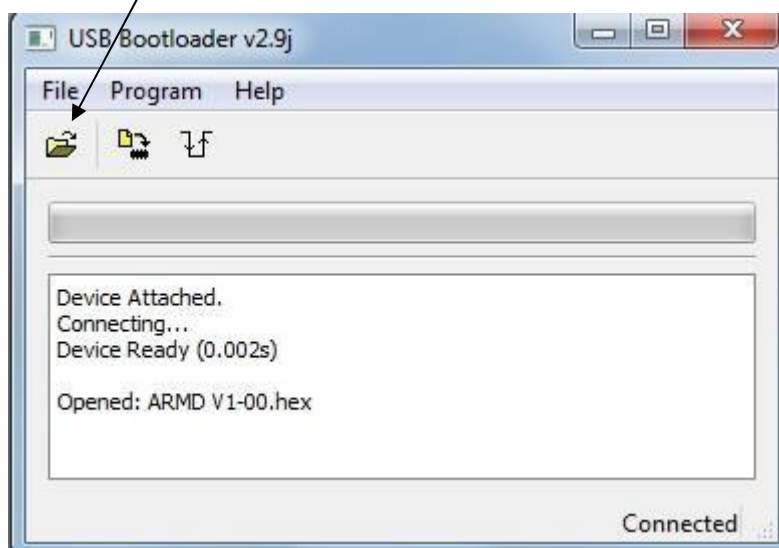

Launch the updates

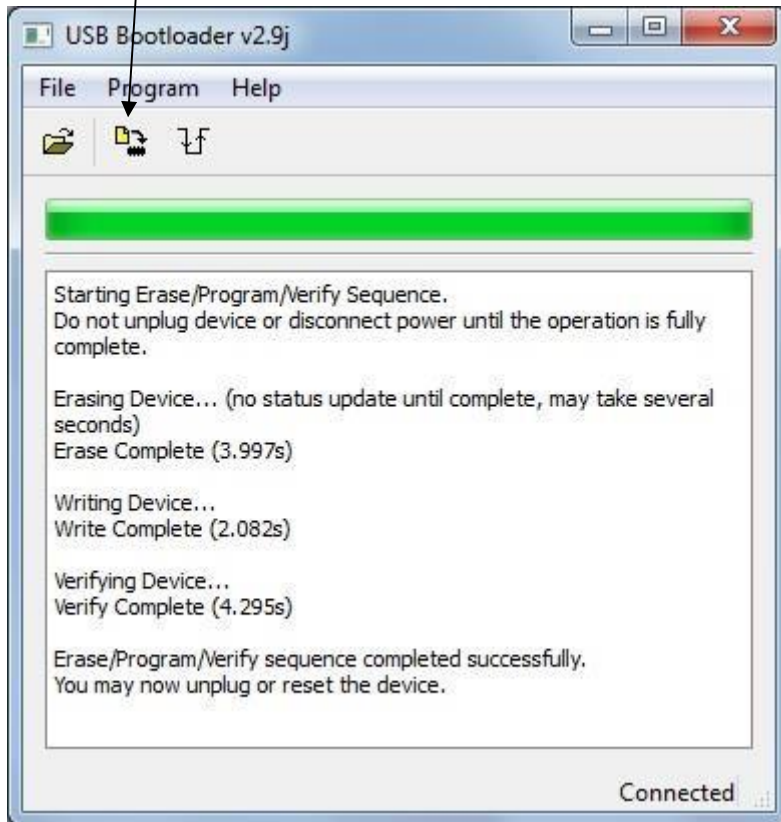

At the end of the programming:

- Turn off the power
- Disconnect the USB cable
- Set the encoder wheel to a position other than 0
- Wait 20s
- Turn on the power (USB connector not connected)
- LED 7 Rx / Fault (Green / Red LED) turns on and off, LED 1 (power) turns on: the modem is ready for operation

#### Note

On power up if no LED is lit, the USB cable is not connected

On power-up if the LED 7 fault LED (Red LED) is flashing, the modem is not programmed, the USB cable is not connected, or the encoder wheel is not 0

After programming and restarting (without USB connector, if the 7 Rx LED / fault LED (Green / Red LED) is flashing continuously, turn off the power and wait 30s before replacing it.

### 3.3 Setup through the configurator

Download the ARM-D configurator software from the ATIM website  
Connect the USB cable

Powering

LED 1 (Power) flashes (200ms / 200ms).

LED 7 Rx (Green Led) flashes (20ms / 800ms)

#### MODBUS configuration

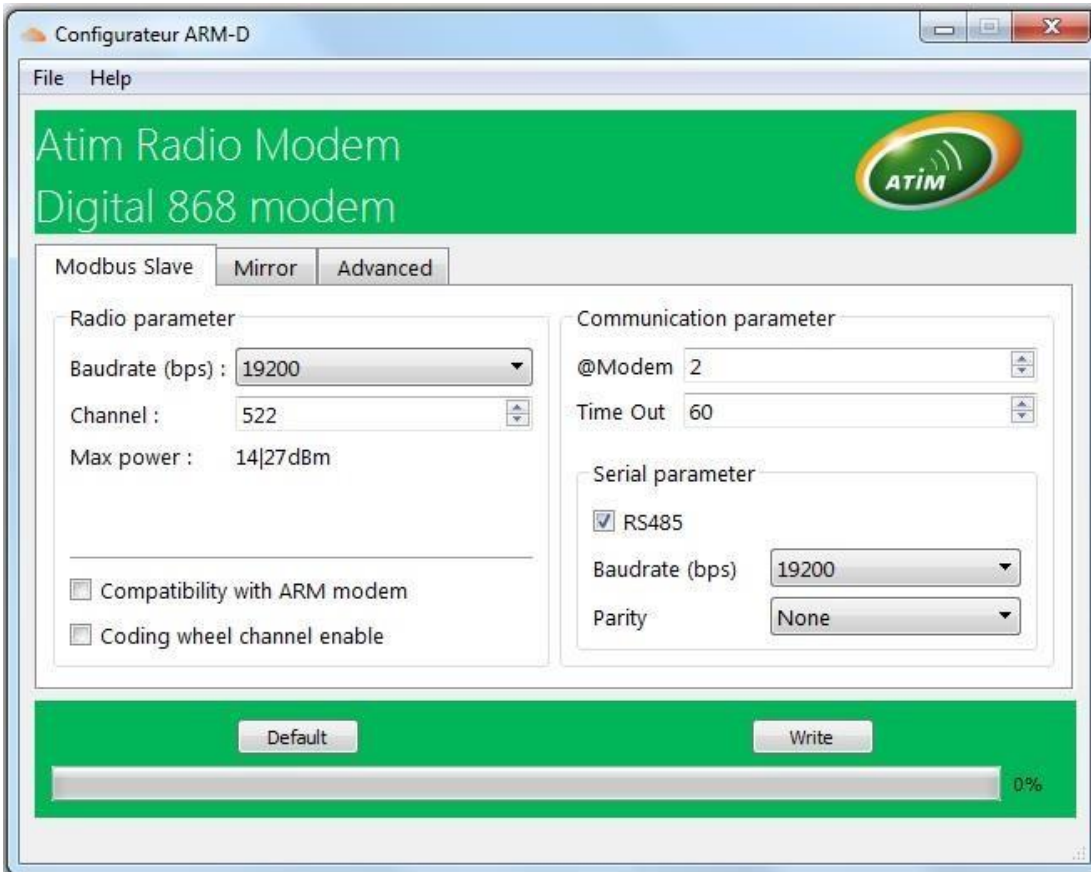

Baudrate : Radio speed: 1200bps to 115000bps for ARM-N8 radio  
9600bps or 19200bps for compatible old modem ARM radio

Channel: Radio Channel Selection (See USER GUIDE ARM N8LD-LP)  
Old ARM modem compatibility: selection from 1 to 15

Compatibility: radio configuration compatible with old modem from the ARM range

Coding wheel: Select the radio channel according to the position of the encoder wheel (See table)

@Modem: MODBUS address (1 to 255)

Time Out: Alarm from 0 to 255 seconds (0 = alarm off)

RS485: RS485 link validation (Option)

Baudrate & Parity: rate and parity control of the serial link

Write: save the configuration after disconnecting the USB cable

Default: Factory reconfiguration of the modem after disconnecting the USB cable

## MIRROR configuration

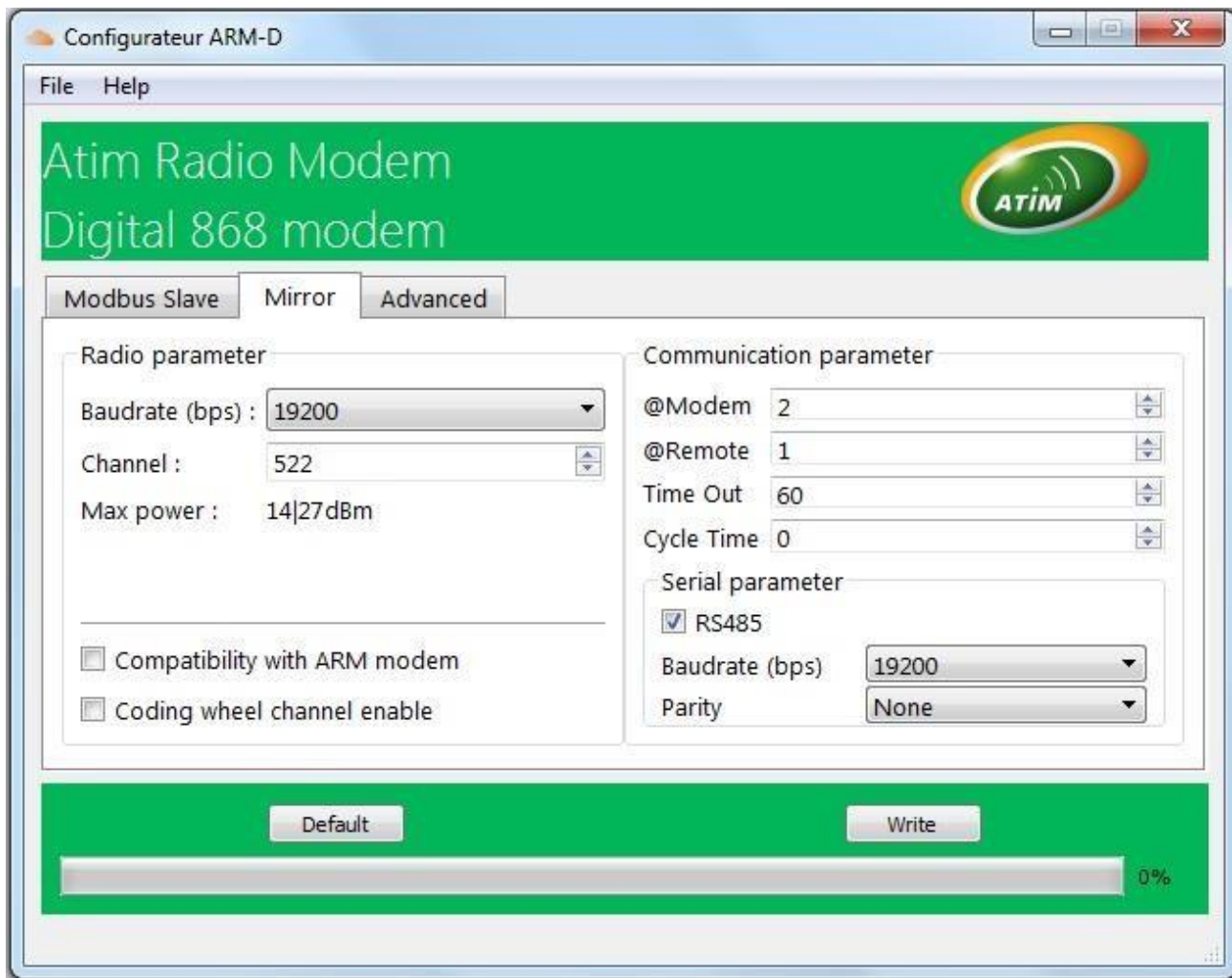

Baudrate: Radio speed: 1200bps to 115000bps for ARM-N8 radio  
9600bps or 19200bps for compatible old modem ARM radio

Channel: Radio Channel Selection (See USER GUIDE ARM N8LD-LP)

Old ARM modem compatibility: selection from 1 to 15

Compatibility

radio configuration compatible with old modem from the ARM range

Coding wheel: selects the radio channel according to the position of the encoder wheel (See table)

@Modem: Local address (1 to 255)

@Remote: destination address (1 to 255)

Time Out: Alarm from 0 to 255 seconds (0 = alarm off)

Cycle Time: Time between 2 cyclic transmissions from 0-255 Time base: 0.5s example for 10s set 20. 0 sets slave mirror mode

RS485: RS485 link validation (Option)

Baudrate & Parity: rate and parity control of the serial link Write: save the configuration after disconnecting the USB cable

Default: Factory reconfiguration of the modem after disconnecting the USB cable

## Mode Advanced

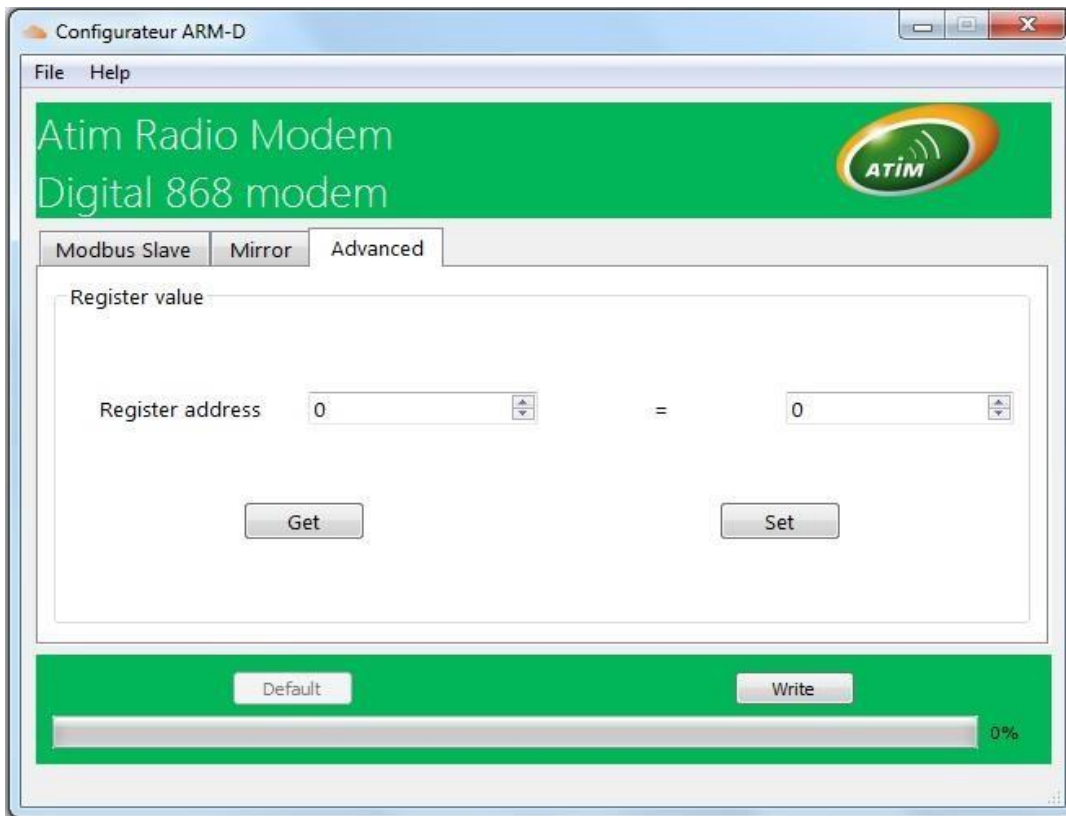

This mode allows access to other modem functions not defined in the other tabs.

The table at the end of the manual defines the addresses of the registers and their functions. The returned or written value is in decimal format

Get: Reading the registry Set: Writing the register Write: Saving changed data

Set: Write the register

Write: save the modified data

### Notes



It is important that, during the configuration time of the ARM-DXXXX modem, it does not receive any radio frame. Otherwise, when memorizing, the LED 7 (Reception / fault) lights up red for a few moments.

After disconnecting the USB cable, the ARM / xxx-D modem performs a "RESET" and resets the memory. As a result, the LED7 (Receive / Fault) may flash or remain fixed for some time. At the end LED 1 (Power) must be fixed. If LED 7 (Receive / Fault) flashes red for several seconds, then turn off the modem and turn it back on. If the fault persists, contact ATIM.

- Do not turn off the power during setup
- The configuration will be saved after disconnecting the USB cable
- Switching between tabs (MODBUS and MIRROR) does not save settings unless there is a data record
- Saving the configuration in the MODBUS or MIRROR tab may lose the information saved in the ADVANCED tab

## 4 Operating mode

### 4.1 Inputs-Outputs Modbus mode access

The ARMD radio modem operates in Modbus RTU slave. The Modbus frame includes (send and answer):

- Slave number (8bits) (number 0 = general broadcast: all slaves no answer)
- Function
- data
- CRC (16bits)

MODBUS functions used by the modem:

*One register writing (Function code: 06):*

<Function \$06> <Register address(\$0000-\$FFFF)><value (\$0000-\$FFFF > Answer:

<function \$06> <Register address(\$0000-\$FFFF)><value (\$0000-\$FFFF > Error

<function \$86><error code \$01 - \$04>

*N register's word reading (Function Code: 03):*

<Function \$03> <Beginning word address (0000-FFFF)><N register name (0001-007D)>

Answer <function \$03><Number of bytes (2\*N)><Register valuer N\*2bytes>

Error <function \$83><error code \$01 - \$04>

*Multiple register's word writting (Function code: 16):*

<Function \$10> <Word address (\$0000-\$FFFF)><Number of register N (\$0001-\$0078)>

<Number of bytes 2\*N> <value 2\*N>

Answer: <function \$10> <Word address(\$0000-\$FFFF)>< Number of register N (\$0001-\$007B)>

Error <function \$90><error code \$01 - \$04>

*One register writing (Function code: 06):*

<Function \$06> <Register address(\$0000-\$FFFF)><value (\$0000-\$FFFF >

Answer: <function \$06> <Register address(\$0000-\$FFFF)><value (\$0000-\$FFFF >

Error <function \$86><error code \$01 - \$04>

Measurement ARMD Modem Response Times: Measured timeout on the serial link of the modem configured in transparent mode connected to a PC transmitting the MODBUS requests to the ARMD slave (Serial link time not considered).

Reading or writing delay logical input or output: <100ms



MODBUS ADDRESS TABLE

Address Hexa	Address Decimal	DESIGNATION	Multiple register access
0000	0	Direct digital inputs reading b0: Input 1 state b1: Input 2 state b2: Input 3 state (Girl card option position 1) b3: Input 4 state (Girl card option position 2) b4: Input 5 state (Girl card option position 3) b5: Input 6 state (Girl card option position 4) b6.b15: non used	No
0010	16	Direct digital outputs reading and writing b0: Output 1 b1: Output 2 b2: Output 3 (Girl card option position 1) b3: Output 4 (Girl card option position 2) b4: Output 5 (Girl card option position 3) b5: Output 6 (Girl card option position 4) b6.b15: non used	No
0020 A 0023	32	Direct reading of analogic input 0-20mA 0mA Value 0000 20mA Value 0FFF (4095pts)	No
0030 A 0033	48	Direct reading and writing of analogic input 0-20mA 0mA Value 0000 20mA Value 0FFF (4095pts)	No
0040	64	Reading and writing meter LSB Input 1 Value b15 to b0	No
0041	65	Reading and writing meter LSB Input 2 Value b15 to b0	No
0042	66	Reading and writing meter LSB Input 3 (Option) Value b15 to b0	No
0043	67	Reading and writing meter LSB Input 4 (Option) Value b15 to b0	No
0044	68	Reading and writing meter LSB Input 5 (Option) Value b15 to b0	No
0045	69	Reading and writing meter LSB Input 6 (Option) Value b15 to b0	No
0050	80	Writing \$A7B5 Intern memory deleting Configuration register: (Reading and writing MODBUS register 0x80 à 0xFF)	No
0051	81	Do not use	No
0052	82	Writing \$A7B5 Calculus and memorization CRC EEPROM After memorization, there is a modem reset	No
0060	96	Test mode function access Writing on the address 96 given from 0 to 15 (See TEST) Test length: register S47-48 (Ad Mb : 0xBF-0xC0)	No

		Default value 2mn (bt:200ms) Modem reset at the end of the test	
0070		Do not use	No
0071		Do not use	No
0078		Reading and writing of number Bloc EEPROM	No
007F	127	Writing \$A7B5 Reset ARMD	No
0080 à 00FF	128 à 255	Reading and writing of memorized registers EEPROM See Command table AT Address 0x80 deals with register S00 etc...	No
0500	1280	Reading and writing register confirmation b0: b1: b2: b3: b4: b5: b6: b7: b8.b15:	YES
0501	1281	Direct digital inputs reading and writing b0: Input 1 state b1: Input 2 state b2: Input 3 state (Girl card option position 1) b3: Input 4 state (Girl card option position 2) b4: Input 5 state (Girl card option position 3) b5: Input 6 state (Girl card option position 4) b6.b15: non used	YES
0502	1282	Digital memorized inputs reading and writing b0: Input 1 state b1: Input 2 state b2: Input 3 state (Girl card option position 1) b3: Input 4 state (Girl card option position 2) b4: Input 5 state (Girl card option position 3) b5: Input 6 state (Girl card option position 4) Deletion by writing 0	YES
0503	1283	Digital outputs reading and writing b0: Output 1 b1: Output 2 b2: Output 3 (Girl card option position 1) b3: Output 4 (Girl card option position 2) b4: Output 5 (Girl card option position 3) b5: Output 6 (Girl card option position 4) b6.b15: non used	YES
0504	1284	Digital output reading and writing command 1 b0: Output 1 b1: Output 2 b2: Output 3 (Girl card option position 1) b3: Output 4 (Girl card option position 2)	YES

		b4: Output 5 (Girl card option position 3) b5: Output 6 (Girl card option position 4) b6.b15: non used	
0505	1285	Digital output reading and writing command 1 b0: Output 1 b1: Output 2 b2: Output 3 (Girl card option position 1) b3: Output 4 (Girl card option position 2) b4: Output 5 (Girl card option position 3) b5: Output 6 (Girl card option position 4) b6.b15: non used	YES
0506	1286	Digital blinking reading and writing outputs b0: Output 1 b1: Output 2 b2.b15: Non used	YES
0507	1287	Digital input 1 reading and writing State 0: value 0000; State 1: value 00FF	YES
0508	1288	Digital input 2 reading and writing State 0 value 0000; State 1: value 00FF	YES
0509	1289	Digital input 3 reading and writing (option) State 0 value 0000; State 1: value 00FF	YES
050A	1290	Digital input 4 reading and writing (option) State 0 value 0000; State 1: value 00FF	YES
050B	1291	Digital input 5 reading and writing (option) State 0 value 0000; State 1: value 00FF	YES
050C	1292	Digital input 5 reading and writing (option) State 0 value 0000; State 1: value 00FF	YES
050D	1293	Digital input 6 reading and writing (non-used) State 0 value 0000; State 1: value 00FF	YES
050E	1294	Digital input 7 reading and writing (non-used) State 0 value 0000; State 1: value 00FF	YES
050F	1295	Digital memorized input 1 reading and writing State 0: value 0000; State 1: value 00FF	YES
0510	1296	Digital memorized input 2 reading and writing State 0: value 0000; State 1: value 00FF	YES
0511	1297	Digital memorized input 3 reading and writing (option) State 0: value 0000; State 1: value 00FF	YES
0512	1298	Digital memorized input 4 reading and writing (option) State 0: value 0000; State 1: value 00FF	YES
0513	1299	Digital memorized input 5 reading and writing (option) State 0: value 0000; State 1: value 00FF	YES
0514	1300	Digital memorized input 6 reading and writing (option) State 0: value 0000; State 1: value 00FF	YES
0515	1301	Digital memorized input 7 reading and writing (non-used) State 0: value 0000; State 1: value 00FF	YES
0516	1302	Digital memorized input 8 reading and writing (non-used) State 0: value 0000; State 1: value 00FF	YES
0517	1303	Digital output 1 reading and writing State 0: value 0000; State 1: value 00FF	YES
0518	1304	Digital output 2 reading and writing State 0: value 0000; State 1: value 00FF	YES

0519	1305	Digital output 3 reading and writing (option) State 0: value 0000; State 1: value 00FF	YES
051A	1306	Digital output 4 reading and writing (option) State 0: value 0000; State 1: value 00FF	YES
051B	1307	Digital output 5 reading and writing (option) State 0: value 0000; State 1: value 00FF	YES
051C	1308	Digital output 6 reading and writing (option) State 0: value 0000; State 1: value 00FF	YES
051D	1309	Digital output 7 reading and writing (non-used) State 0: value 0000; State 1: value 00FF	YES
051E	1310	Digital output 8 reading and writing (non-used) State 0: value 0000; State 1: value 00FF	YES
051F	1311	Analogic value Way 1 reading and writing 0mA Value 0000 20mA Value 0FFF (4095)	YES
0520	1312	Analogic value Way 2 reading and writing (option) 0mA Value 0000 20mA Value 0FFF (4095)	YES
0521	1313	Analogic value Way 3 reading and writing (option) 0mA Value 0000 20mA Value 0FFF (4095)	YES
0522	1314	Analogic value Way 4 reading and writing (option) 0mA Value 0000 20mA Value 0FFF (4095)	YES
0523	1315	Analogic value Way 5 reading and writing (non-used) 0mA Value 0000 20mA Value 0FFF (4095)	YES
0524	1316	Analogic value Way 6 reading and writing (non-used) 0mA Value 0000 20mA Value 0FFF (4095)	YES
0525	1317	Analogic value Way 7 reading and writing (non-used) 0mA Value 0000 20mA Value 0FFF (4095)	YES
0526	1318	Analogic value Way 8 reading and writing (non-used) 0mA Value 0000 20mA Value 0FFF (4095)	YES
0527	1319	Analogic value Way 1 reading and writing (after conversion)	YES
0528	1320	Analogic value Way 2 reading and writing (option) (after conversion)	YES
0529	1321	Analogic value Way 3 reading and writing (option) (after conversion)	YES
052A	1322	Analogic value Way 3 reading and writing (option) (after conversion)	YES
052B	1323	Analogic value Way 1 reading and writing (non-used) (after conversion)	YES
052C	1324	Analogic value Way 1 reading and writing (non-used) (after conversion)	YES
052D	1325	Analogic value Way 1 reading and writing (non-used) (after conversion)	YES
052E	1326	Analogic value Way 1 reading and writing (non-used) (after conversion)	YES
052F	1327		YES

0530	1328	Rising edge meter reading and writing INP1 (LSB)	YES
0531	1329	Rising edge meter reading and writing INP1 (MSB)	YES
0532	1330	Rising edge meter reading and writing INP2 (LSB)	YES
0533	1331	Rising edge meter reading and writing INP2 (MSB)	YES
0534	1332	Rising edge meter reading and writing INP3 (LSB)	YES
0535	1333	Rising edge meter reading and writing INP3 (MSB)	YES
0536	1334	Rising edge meter reading and writing INP4 (LSB)	YES
0537	1335	Rising edge meter reading and writing INP4 (MSB)	YES
0538	1336	Rising edge meter reading and writing INP5 (LSB)	YES
0539	1337	Rising edge meter reading and writing INP5 (MSB)	YES
053A	1338	Rising edge meter reading and writing INP6 (LSB)	YES
053B	1339	Rising edge meter reading and writing INP6 (MSB)	YES
053C	1340	Rising edge meter reading and writing INP7 (LSB)	YES
053D	1341	Rising edge meter reading and writing INP7 (MSB)	YES
053 <sup>E</sup>	1342	Rising edge meter reading and writing INP8 (LSB)	YES
053F	1343	Rising edge meter reading and writing INP8 (MSB)	YES
			YES
0540	1344	Falling edge meter reading and writing INP1 (LSB)	YES
0541	1345	Falling edge meter reading and writing INP1 (MSB)	YES
0542	1346	Falling edge meter reading and writing INP2 (LSB)	YES
0543	1347	Falling edge meter reading and writing INP2 (MSB)	YES
0544	1348	Falling edge meter reading and writing INP3 (LSB)	YES
0545	1349	Falling edge meter reading and writing INP3 (MSB)	YES
0546	1350	Falling edge meter reading and writing INP4 (LSB)	YES
0547	1351	Falling edge meter reading and writing INP4 (MSB)	YES
0548	1352	Falling edge meter reading and writing INP5 (LSB)	YES
0549	1353	Falling edge meter reading and writing INP5 (MSB)	YES
054A	1354	Falling edge meter reading and writing INP6 (LSB)	YES
054B	1355	Falling edge meter reading and writing INP6 (MSB)	YES
054C	1356	Falling edge meter reading and writing INP7 (LSB)	YES
054D	1357	Falling edge meter reading and writing INP7 (MSB)	YES
054 <sup>E</sup>	1358	Falling edge meter reading and writing INP8 (LSB)	YES
054F	1359	Falling edge meter reading and writing INP8 (MSB)	YES
			YES
0550	1360	Reserved	YES
0551	1361	Reserved	YES
0552	1362	Reserved	YES
0553	1363	Reserved	YES
0554	1364	Reserved	YES
0555	1365	Reserved	YES
0556	1366	Reserved	YES
0557	1367	Reserved	YES
0558	1368	Reserved	YES
0559	1369	Reserved	YES
055A	1370	Reserved	YES
055B	1371	Reserved	YES
055C	1372	Reserved	YES
055D	1373	Reserved	YES
055 <sup>E</sup>	1374	Reserved	YES
055F	1375	Reserved	YES
0560	1376	Reserved	YES

0561	1377	Reserved	YES
0562	1378	Reserved	YES
0563	1379	Reserved	YES
0564	1380	Reserved	YES
0565	1381	Reserved	YES
0566	1382	Reserved	YES
0567	1383	Reserved	YES
0568	1384	Reserved	YES
0569	1385	Reserved	YES
056A	1386	Reserved	YES
056B	1387	Reserved	YES
056C	1388	Reserved	YES
056D	1389	Reserved	YES
056 <sup>E</sup>	1390	Reserved	YES
056F	1391	Reserved	YES
			YES
0570	1328	Analogic 1 higher threshold level reading and writing	YES
0571	1329	Analogic 2 higher threshold level reading and writing	YES
0572	1330	Analogic 3 higher threshold level reading and writing	YES
0573	1331	Analogic 4 higher threshold level reading and writing	YES
0574	1332	Analogic 1 lower threshold level reading and writing	YES
0575	1333	Analogic 2 lower threshold level reading and writing	YES
0576	1334	Analogic 3 lower threshold level reading and writing	YES
0577	1335	Analogic 4 lower threshold level reading and writing	YES
0578	1336	Writing and reading non-used	YES
0579	1337	Writing and reading non-used	YES
057A	1338	Writing and reading non-used	YES
057B	1339	Writing and reading non-used	YES
057C	1340	Reserved	YES
057D	1341	Reserved	YES
057 <sup>E</sup>	1342	Reserved	YES
057F	1343	Reserved	YES

LSB: bit15 to bit0 from the meter value 32bits  
MSB: bit31 to bit16 from the meter value 32bits

## Remarks



- The memorized input corresponds to the detection of a rising edge of the corresponding logic
- input, the register must be reset by a MODBUS command in order to detect a new transition
- For logic outputs, the priority is first the blinking of the output, then the setting to 1.
- Each entry has a 32bit counter
- The counters are reset to 0 by writing 0 counter registers by MODBUS command Note for Modifying

### Configuration Registers:

- Reading of the register to be modified (ex: MODBUS address modification -> S07 register => Modbus register address 0x87)
- Write the value to modify (Modbus register address 0x87)
- Modified register storage: write 0xA7B5 at address 0x52

## 4.2 Inputs-Outputs Mirror mode access

This function has 3 modes:

- Simple master mirror mode: In this configuration, the master modem and the slave modem have identical configuration of the inputs and outputs, the master modem sends a radio frame representing the state of its inputs to the slave modem which copies the state of the inputs received on its outputs and which immediately returns the status of its inputs to the master modem. The master modem sends the frame either according to a defined cycle, or on a change of state of its digital inputs
- Multiple master mirror mode:  
Possible modem configurations:  
ARM/868-D2200 <-> 2 \* ARM/868-D2200 (Assignment 1 input output)  
ARM/868-D4400 <-> 2 ou 4 ARM/868-D2200 (Assignment 1 or 2 input output)  
ARM/868-D2204 <-> 2 ou 4 ARM/868-D2210 (Assignment 1 input output)  
ARM/868-D2200 + ARM-D88 <-> 5 ou 10 \* ARM/868-D2200 (Assignment 1 or 2 input output)  
ARM/868-D4400 + ARM-D88 <-> 6 ou 12 \* ARM/868-D2200 (Assignment 1 or 2 input output)  
ARM/868-D4400 + 2 \* ARM-D88 <-> 5 \* ARM/868-D4400 (Assignment 4 input output)  
ARM/868-D2200 + 2 \* ARM-D88 <-> 2 \* ARM/868-D2200 + ARM-D88 (Assignment 8 input output)  
ARM/868-D2204 + ARM-D88 <-> 4 ARM/868-D2210 or 2 ARM/868-D2220
- Slave mirror mode: Upon receiving the radio frame transmitted by the master modem, the slave modem copies the remote master's inputs to its outputs and returns the status of its inputs to the master modem.

Multiple options are available:

- Cyclical sending
- Send on state change of a digital input (Simple master mirror mode)
- No return frame transmission Unidirectional mode
- -Inversion of logical inputs

The mode "Send on state change of a digital input" can be used with the cyclic mode. If the sending on change of state is realized, the total duration of the cycle time is restarted immediately.

USB Configuration Mirror Mode Setup @Modem: Local address (1 to 255)

@Remote: destination address (1 to 255)

Time Out: Alarm from 0 to 255 seconds (0 = alarm off)

Cycle Time: Time between 2 cyclic transmissions from 0-255 Time base: 0.5s example for 10s set 20. 0 sets slave mirror mode



USB Advanced Mode setting:

Register Used by Mirror Mode:

S001: Application Register 2:

- B0: Mirror mode frame compatible ARM-D
- B1: Mirror mode frame compatible ARM-DA
- B2: Do not use
- B3: Cyclic Mode Validation
- B4: State change transmission of logic inputs
- B5: Unidirectional mode No frame between slave and master
- B6: Do not use
- B7: Do not use

S008: Local address

S009: Destination address

S023: Waiting Time Response (Slave = 0x02) (Master = 0A) S025: Cycle time between 2 frames (LSB) (Bt: 0.25ms) S026:

Cycle time between 2 frames (MSB) (Bt: 0.25ms)

S027: Multiple cycle time

#### Note

Using one to use a low radio rate (<4800b / s) results in longer delays, so it may be necessary to increase the waiting time of the S023 register.

Specific setups:

- Compatibility for ARM-D: Bit0 of the S01 register activated (= 1)
- Compatibility for ARM-X: S01 register bit0 disabled (= 0)

Register Configurations to Validate Mirror Multiple Mode:

Register S000 = 04: multiple mirror mode

S060 register: number of remote slave modem

Register S044 (Bit 3): if = 1 => Assignment 1 digital input and 1 digital output otherwise assignment 2 IO Register

S044 (Bit 5,6,7): 000 = Slave ARMD2200; 001 Slave ARMD4400; 010 Slave ARMD88; 100 = Slave ARMD2210 or ARMD2220

ARM-D88 setup configuration

RS485 validation: bit7 register S13

RS485 validation MODBUS mode : bit0 register S30

Number of D88 Modems on RS485 Link: S57

Alarm Management in Multiple Mirror Mode:

An alarm (radio communication fault) is automatically assigned to each slave modem: If a fault occurs (radio communication break) between the master modem and a slave modem, then only the outputs of the master assigned to the slave modem fall back. This alarm is invalid if there are analog inputs.

S51 register Alarm time on each modem (Bt cycle time)

### 4.3 Repeater function

Repeater mode non available

### 4.4 Watchdog alarm

The validation of the watchdog makes it possible to control the non-reception of radio frame for a given time. At the end of the determined time without radio frame detection, the modem puts its outputs in the fallback position and can activate its alarm output.

The ARM-D has a logic output used by default by the alarm function.

USB configuration Configuration MODBUS mode or MIRROR

Time Out: Alarm from 0 to 255 seconds (0 = alarm off)

USB Advanced Mode setting:

Register Used by Mirror Mode:

S034: Register Application 3:

B0: Validation Alarm Output 3

B1: Reset enable if the alarm tempo is activated twice

B2: Do not use

B3: Validation Alarm

B4: Validation Outputs in Fallback Position (S000 Register)

B5: Do not use

B6: Reverse State Alarm Output

B7: Reset radio card reset if the alarm tempo is activated twice

S069: Register Fallback position of the outputs

S052: Alarm delay (LSB) (Bt: 200ms)

S053: Alarm Timeout (MSB) (Bt: 200ms)

### 4.5 Standby mode

Standby mode non available (except for SIGFOX mode)

## 4.6 SIGFOX mode

The ARM/SF8-DXXXX modem is already preconfigured to access the SIGFOX network.

On power-up or after a reset, the modem sends a first SIGFOX functional frame 10 seconds after the power supply, then returns 20 seconds after a second SIGFOX frame, then 30 seconds after a third frame and then the modem goes into normal operation.

There are several modes of working that are independent of each other.

### Mode of detection on change of state of the logical inputs:

The modem has 2 logic inputs by default, and it is possible to add 4 additional logic inputs. A state change on one logic input triggers the sending of a SIGFOX frame. The modem does not go into sleep mode and must remain powered

Register setup:

- Register S041 bit 0: Function validation
- S042 register bit 0 to 3: Logic input 1 and 2 inputselection

SIGFOX frame:

Octet 1: 0x33

Octet 2 : XX : bit0 logical input state 1; bit1 logical input state 2

### Analog inputs threshold detection mode

It is possible to have 4 analog inputs. The detection is done on a high-level threshold and a low-level threshold. The software performs a measurement of the analog inputs every 3 minutes, this time is configurable. If a threshold is detected, the software sends a SIGFOX frame. The modem does not go into sleep mode and must remain powered.

Register setup:

- Register S041 bit 2: Validation read analog input
- Register S042 bit 4: Analog threshold detection function
- Register S016-S015: Time between 2 readings of analog inputs -Bt = 100ms Default value: 0x0708 (3mn)
- High level analog threshold register: S125-S124 (input 1); S127-S126 (entry 2); S129-S128 (entry 3); S131-S130 (input 4)
- Low level analog threshold register: S132-S131 (input 1); S134-S133 (entry 2); S136-S135 (entry 3); S138-S137 (entry 4)

SIGFOX frame:

Octet 1: 0x36

Byte 2: XX: bit0 logical input state 1; bit1 logical input state 2 Byte 3: YY: bit0 to 3 presence analog input card

Byte 4, 5: analog input value 1 (0000-OFFF)

Byte 6, 7: analog input value 2 (0000-OFFF)

Byte 8, 9: analog input value 3 (0000-OFFF)

Byte 10, 11: analog input value 4 (0000-OFFF)

### Analog inputs threshold detection mode

It is possible to have 4 analog inputs. The detection is done on a predefined variation in a register. The software performs a measurement of the analog inputs every 3 minutes, this time is configurable. If the value exceeds this variation, the software sends a SIGFOX frame. The modem does not go into sleep mode and must remain powered.

Register of configuration :

- Register S041 bit 2: Validation read analog input
- Register S042 bit 5: Validation function analog value variation
- Register S016-S015: Time between 2 readings of analog inputs -Bt = 100ms Default value: 0x0708 (3mn)
- High-level analogue dimming value register: S125-S124 (input 1); S127-S126 (entry 2); S129- S128 (entry 3); S131-S130 (input 4)
- Low-level analogue variation value register: S132-S131 (input 1); S134-S133 (entry 2); S136- S135 (entry 3); S138-S137 (entry 4)

SIGFOX frame:

Octet 1: 0x36

Byte 2: XX: bit0 logical input state 1; bit1 logical input state 2 Byte 3: YY: bit0 to 3 presence analog input card

Byte 4, 5: analog input value 1 (0000-OFFF)

Byte 6, 7: analog input value 2 (0000-OFFF)

Byte 8, 9: analog input value 3 (0000-OFFF)

Byte 10, 11: analog input value 4 (0000-OFFF)

### **Cyclic Send mode of counters for digital inputs 1 and 2**

The modem has 2 default logic inputs that are used as a 32-bit counter and it is possible to add 4 additional logic inputs. For the meters it is necessary to respect the technical characteristics for the considering of the information. The modem cyclically sends a SIGFOX frame. The cycle time is 10mn multiple and is configurable by register. The modem does not go into sleep mode and must remain powered. The counters are reset if the modem is no longer powered or after a reset of the modem. The values of the counters can be saved.

Register setup:

- Register S041 bit 1: Validation Sends cyclic counter
- S042 register bit 0 to 3: Logic input 1 and 2 input selection
- Register S041 bit 6: Backup counter
- Register S46: Cycle time (bt: 10mn)

SIGFOX frame:

Octet 1: 0x34

Byte 2: XX: bit0 logical input state 1; bit1 logical input state 2 Byte 3, 4, 6, 7: Logic input counter value 1

Octet 8, 9, 10, 11: Logic input counter value 2

## Mode Sends cyclic analog inputs

It is possible to have 4 analog inputs. The software performs a measurement of the analog inputs every 3 minutes, this time is configurable. The modem cyclically sends a SIGFOX frame. The cycle time is 10mn multiple and is configurable by register. It is possible to go into sleep mode between 2 cycles, in which case the software reads the analog inputs before sending the SIGFOX frame.

Register setup:

- Register S041 bit 2: Validation read analog input
- Register S042 bit 6: Validation function sends cyclic analog values
- Register S016-S015: Time between 2 readings of analog inputs -Bt = 100ms Default value: 0x0708 (3mn)

SIGFOX frame:

Octet 1: 0x35

Byte 2: XX: bit0 logical input state 1; bit1 logical input state 2 Byte 3: YY: bit0 to 3 card analog input

Byte 4, 5: analog input value 1 (0000-0FFF)

Byte 6, 7: analog input value 2 (0000-0FFF)

Byte 8, 9: analog input value 3 (0000-0FFF)

Byte 10, 11: analog input value 4 (0000-0FFF)

## Remark

- The Alarm function is not valid in this mode
- The Sleep Mode function can be used in some modes. In standby mode, the power LED flashes for a few milliseconds every 16 seconds. The registers used are:
  - Register S040 bit 1: Validation Standby Mode
  - Register S065-S064: Standby time (bt: 16s) Ex: About 15mn S65 = 00 S64 = 56
  - Register S46 = 01: Cycle time: set the value 1
  - Register S27 = 01: Cycle time: set the value 1

The consumption is about 3 mA in standby mode.

- Function logic outputs active (inactive during sleep mode)
  - Register S040 bit 2: Logical output validation
- Uncertainty over time: The uncertainty is related to the drifts and the tolerance of the components. The uncertainty of the periodic sending is +/- 16s. It is possible to have a drift in time; in this case the periodic sending can shift.

## Consumption

The test is performed on an ARM / 868-D2220 modem.

The 2 digital outputs are active during receive and transmit mode (No load connected)

The 2 analog inputs are not wired

The 2 digital inputs are not wired Receive mode duration: 20s

Duration of transmission mode: 10s

Modem standby time: 15 minutes

	Reception current	Emission current	Standby current
Tension 12V	30mA	70mA	<5mA
Tension 24V	15mA	30mA	<2.5mA

Used registers:

Application register 8 : S041

- b0: SIGFOX: Validation detection change of state digital input
- b1: SIGFOX: Validation sends periodic counter logical input 1 and 2
- b2: SIGFOX: Analog input readout
- b3: Do not use (= 0)
- b4: Do not use (= 0)
- b5: Do not use (= 0)
- b6: Do not use (= 0)
- b7: Do not use (= 0)

Application register 7: S042

- b0: Logic input 1: rising edge
- b1: Logic Input 1: Falling Edge
- b2: Logic input 2: rising edge
- b3: Logic Input 2: Falling Edge
- b4: SIGFOX: Analog input threshold trigger
- b5: SIGFOX: Analog input trigger on variation of the value
- b6: SIGFOX: Analogue input periodic trigger
- b7: Do not use (= 0)

**ACCESS TO DATA ON ATIM PLATFORM**

Log on to the web platform <http://acw.atim.com> to access your devices and view your data. Your login details will be provided by email to the shipping of your order.

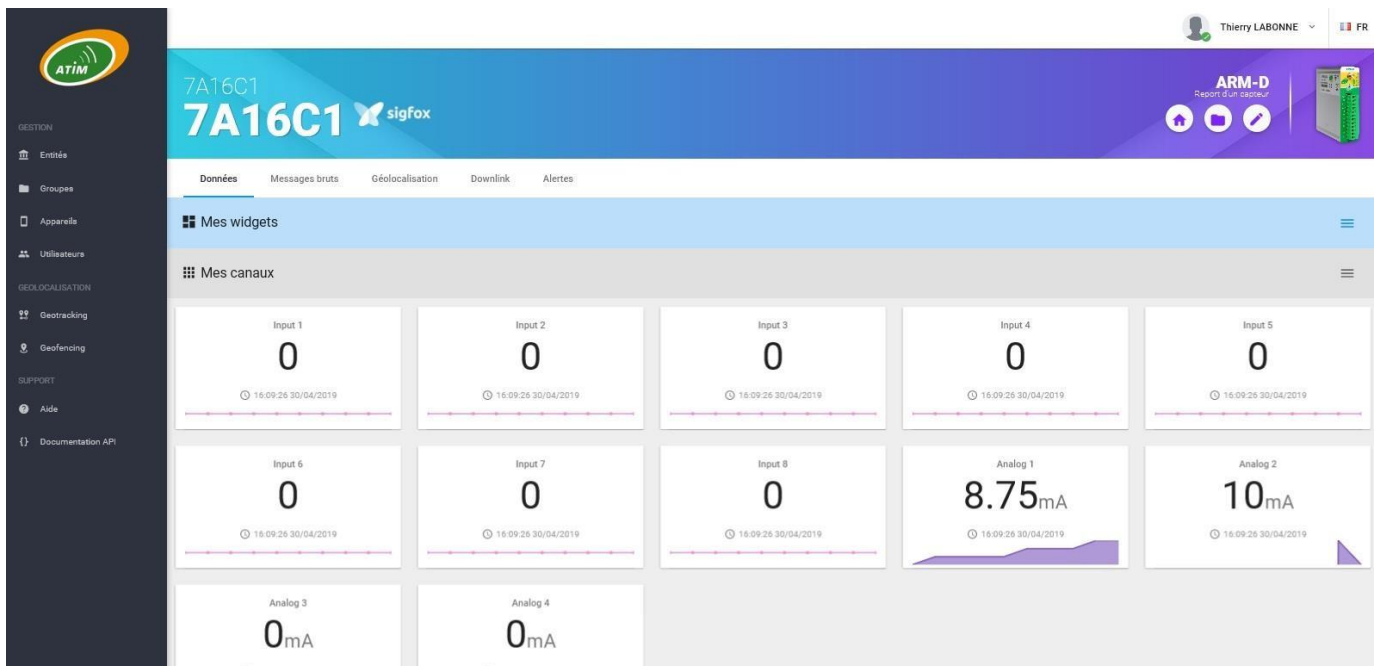

4.7 Mode LORAWAN

The ARM / LW8-DXXXX modem is already preconfigured to access the LORAWAN network after activating the modem on the network.

On power-up or after a reset, the modem sends a first functional LORAWAN frame 10 seconds after powering on, then returns 20 seconds after a second LORAWAN frame then 30 seconds after a third frame then the modem starts up in normal operation.

There are several operating modes which are independent of each other.

### **Detection mode on change of state of logic inputs**

The modem has 2 logic inputs by default, and it is possible to add 4 additional logic inputs. A change of state on 1 logic input triggers the sending of a LORAWAN frame. The modem does not go into sleep mode and must remain powered.

Register of configuration:

- Register S041 bit 0: Function validation
- Register S042 bit 0 to 3: Edge selection of logic input 1 and 2

LORAWAN frame :

Octet 1 : 0x33

Octet 2: XX: bit0 logic input 1 state; bit1 logic input 2 state

### **Analog input threshold detection mode**

It is possible to have 4 analog inputs. Detection is done on a high-level threshold and a low level threshold. The software measures the analog inputs every 3 minutes, this time can be configured. If a threshold is detected, the software sends a LORAWAN frame. The modem does not go into sleep mode and must remain powered.

Register of configuration:

- Register S041 bit 2: Analog input reading validation
- Register S042 bit 4: Enable analog threshold detection function
- Register S016-S015: Time between 2 readings of the analog inputs -Bt = 100ms Default value: 0x0708 (3mn)
- Higher analog threshold register: S125-S124 (input 1); S127-S126 (input 2); S129-S128 (input 3); S131-S130 (input 4)
- Lower analog threshold register: S133-S132 (input 1); S135-S134 (input 2); S137-S136 (input 3); S139-S138 (input 4)

LORAWAN frame:

Octet 1: 0x36

Octet 2: XX: bit0 logic input 1 state; bit1 logic input 2 state

Octet 3: YY: bit0 at 3 analog input card presence

Octet 4 ,5: analog input value 1 (0000-0FFF)

Octet 6 ,7: analog input value 2 (0000-0FFF)

Octet 8 ,9: analog input value 3 (0000-0FFF)

Octet 10 ,11: analog input value 4 (0000-0FFF)

### **Digital counters inputs 2 and 2 cyclic mode emission**

The modem has 2 logic inputs by default which are used as a 32-bit counter and it is possible to add 4 additional logic inputs. For meters, the technical characteristics must be respected to take the information into account. The modem cyclically sends a LORAWAN frame. The cycle time is a multiple of 10 minutes and can be configured by register. The

modem does not go into sleep mode and must remain powered. The counters are reset to zero if the modem is no longer powered or following a modem reset. Counter values can be saved.

Register of configuration :

- Registre S041 bit 1: Cyclic counting emission validation
- Registre S042 bit 0 to 3: Edge selection of logic input 1 and 2
- Registre S041 bit 6: Counter backup
- Registre S46: Cycle time (bt :10mn)

LORAWAN frame:

Octet 1: 0x34

Octet 2: bit0 logic input 1 state; bit1 logic input 2 state

Octet 3, 4, 6, 7: value of the counter of logical input 1

Octet 8, 9, 10, 11: value of the counter of logical input 2

### Analog input cyclic mode emission

It is possible to have 4 analog inputs. The software measures the analog inputs every 3 minutes, this time can be configured. The modem cyclically sends a LORAWAN frame. The cycle time is a multiple of 10 minutes and can be configured by register. It is possible to go into standby mode between 2 cycles, in this case the software reads the analog inputs before sending the LORAWAN frame.

Register of configuration:

- Register S041 bit 2: Analog input reading validation
- Register S042 bit 4: Enable analog threshold detection function
- Register S016-S015: Time between 2 readings of the analog inputs -Bt = 100ms Default value: 0x0708 (3mn)

LORAWAN frame:

Octet 1 : 0x35

Octet 2: XX: bit0 logic input 1 state; bit1 logic input 2 state

Octet 3: YY: bit0 at 3 analog input card presence

Octet 4 ,5: analog input value 1 (0000-0FFF)

Octet 6 ,7: analog input value 2 (0000-0FFF)

Octet 8 ,9: analog input value 3 (0000-0FFF)

Octet 10 ,11: analog input value 4 (0000-0FFF)



## Note

- The alarm function is not available in this mode
  - The Sleep Mode function can be used in some modes. While in standby mode, the Power LED blinks for a few milliseconds every 16 seconds. The registers used are:
    - o Register S040 bit 1: sleep mode validation
    - o Register S065-S064: standby time (bt : 16s) Ex : about 15mn S65=00 S64=56Consumption is about 3 mA in standby mode.
- Used registers if Standby mode is not used
- o Register S46 =01: (Timeframe = 10mn) Cycle time: Default value 1
  - o Register S27 =3C: (Timeframe (Timer1) =10s) Default value: 0x3C = 10mn
- Active digital outputs functions (inactive during standby mode)
    - o Register S040 bit 2: digital output validation
  - Uncertainty of time: The uncertainty is linked to the drifts and the tolerance of the components. The uncertainty of the periodic sending is +/- 16s. It is possible to have a drift in time, in this case the periodic sending may shift.

## Consumption

- Test is operated on an ARM/LW8-D2220 modem
- 2 digital outputs are active during emission and reception modes
- 2 analog inputs are not connected
- 2 Both digital inputs are not connected
- Reception mode duration: 20s
- Emission mode duration: 10s
- Standby mode duration: 15 mn

	Receiving current	Emitting current	Standby current
Tension 12V	30mA	70mA	<5mA
Tension 24V	15mA	30mA	<2.5mA

## Used registers:

- Application register 8: S041
  - b0: LORAWAN: Change of digital input detection validation
  - b1: LORAWAN: Digital inputs 1 and 2 periodic counter emission validation
  - b2: LORAWAN: Analog inputs reading validation
  - b3: Do not use (=0)
  - b4: Do not use (=0)
  - b5: Do not use (=0)

- b6: Do not use (=0)
- b7: Do not use (=0)
  
- Application register 7: S042
- b0: Digital input 1: Rising edge
- b1: Digital input 1: Falling edge
- b2: Digital input 2: Rising edge
- b3: Digital input 2: Falling edge
- b4: LORAWAN: Analog input threshold trigger
- b5: LORAWAN: Analog input triggering on variation of the value
- b6: LORAWAN: Analog input periodic trigger
- b7: Do not use (=0)

### ACCES AUX DONNEES SUR PLATEFORME ATIM

- Connect to the web platform <http://acw.atim.com> to access your devices and view your data. Your login details will be provided to you by email when your order is shipped.

### Example of configuration on ATIM GATEWAY

Setup of the ARM-D:

S040 = 06 (0x06): standby mode and digital output validation

S041 = 04 (0x04): analog input reading validation

S042 = 69 (0x45): cyclic emission validation

S65=00 S64=56: standby time (15mn)

Setup of ATIM's GATEWAY:

The screenshot shows the 'Server Admin' web interface. On the left is a navigation menu with options: Users, Infrastructure, Devices (expanded to show Profiles and Commissioned), Activated (Nodes), Ignored, Backends, and Received Frames. The main content area is titled 'Edit device #70B3D59BA000A3C0' and contains the following configuration fields:

- DevEUI \***: 70B3D59BA000A3C0
- Profile \***: ARMDXXXX\_TEST\_01
- App Arguments**: (empty field)
- AppEUI**: 70B3D59BA0000004
- AppKey \***: 69DB443428C541698E851AB678AB1F9C
- Description**: Modem ARM-DXXXX
- Last Join**: 2018-07-16 18:10:27
- Node**: 01E979A3

At the bottom of the form is a blue button labeled 'Save changes' with a checkmark icon.

## 5 Test Mode

The test mode can be activated either by MODBUS request or by using the USB configurator in the ADVANCED mode. In the ADVANCED mode write to the address 192 by setting the value of the test. In the MODBUS mode write the test value to 0x60 (see MODBUS table). To exit the test modem the power supply of the ARM-D modem must be disconnected.

Test functions:

Test 1	Blinking of the power LED
Test 2	Loosening of the inputs on the outputs and assignment of the encoder wheel on LED
Test 3	Carrier emission (Led mission ON)
Test 4	Do not use
Test 5	Do not use
Test 6	Do not use
Test 7	PING PONG ARM-N8 Master: see description in the ARM-N8 modem installation guide
Test 8	PING PONG Slave ARM-N8: see description in the ARM-N8 modem installation guide
Test 9	Do not use
Test A	Direct communication with the ARM-N8 radio card on a serial link. Usable if the RS485 link (Option) is available)
Test B	Direct communication with the ARM-N8 radio card on a serial link to use the BootLoader. Usable if the RS485 link (Option) is available.
Test C	Do not use
Test D	Factory Reconfiguration of the ARM-D Modem
Test E	Do not use
Test F	Do not use

## 6 Maintenance

General maintenance of ARM radio modems.

The user must comply with the installation instructions. As a result, the modem does not need any special maintenance.

Maintenance of ARM radio modems.

The internal test functions allow the user to check the operation of the ARM-D radio modem in its environment. The user has several tests to use depending on the type of problem

Test D: Factory Reconfiguration

Factory reconfiguration resets the modem configuration.

Warning: all existing configuration will be lost

- Use of configurator ARM-D, "Advanced" tab
- Write to address 192 value 13
- Click on "SET"
- Click on "WRITE"
- Disconnect USB cable: LED 1 (Power) flashes
- Turn off the modem power and wait 5s
- Reset the modem power

Test 7 and 8: Ping Pong Test

This test makes it possible to check the radio link in 2 points.

For this, it is necessary to use 2 modems using the same radio card. Manual description radio ARM-N8

Problem encountered	Probable cause	Solution
Power LED not illuminated	Encoder wheel position 0 No power	Check if the power supply is suitable
No radio reception	Low radio range	Do Ping Pong test Check Antenna wiring Check positioning encoder wheel
Random reception	Low radio range	Do Ping Pong test Check antenna wiring
No radio emission	Incorrect configuration	Check the configuration Do Test Reconfiguration

### Note

When configuring and disconnecting the USB cable, the ARM-D modem performs a "RESET" and resets the memory. As a result, the LED7 (Receive / Fault) may flash or remain fixed for some time. At the end LED 1 (Power) must be fixed.

If LED 7 (Receive / Fault) flashes red for several seconds, then turn off the modem and turn it back on. If the fault persists, contact ATIM.

TABLE OF MODEM ARMD CONFIGURATION REGISTERS

The values of the registers are in hexadecimal format: \$ xx

No	Ad MB	Register use	Default value
S00	008A	Registry Application 1: see detail	0x02
S01	008B	Registry Application 2: see detail	0x00
S02	008C	Radio: Radio Channel Number (LSB)	0x0A
S03	008D	Radio: Radio Channel Number (MSB)	0x02
S04	008E	Radio: Power selection emission	0x00
S05	008F	Radio: Registry Application Radio: see detail	0x10
S06	0090	Radio: Radio Bitrate \$ 01 = 1200; \$ 02 = 2400; \$ 03 = 4800 \$ 04 = 9600; \$ 05 = 19200; \$ 0A = 19200 (ARM); 0B = \$ 9600 (ARM)	0x0A
S07	0091	MODBUS Mode: Local Address	0x01
S08	0092	Mirror mode: Local address	0x11
S09	0093	Mirror Mode: Destination Address	0x12
S10	0094	Do not use	
S11	0095	Do not use	
S12	0096	Serial Link: Serial Link Rate \$ 00 = 1200; \$ 01 = 2400; \$ 02 = 4800; \$ 03 = 9600 \$ 04 = 19200; \$ 05 = 38400; \$ 06 = 76800; \$ 07 = 115200	0x04
S13	0097	Serial link: Control Register B0: parity validation B1: odd (0) / pair (1) B2: 2 bits stop B3: 7-bit validation	0x00
S14	0098	Do not use	
S15	0099	Do not use	
S16	009A	Do not use	
S17	009B	Do not use	
S18	009C	Do not use	
S19	009D	Led Reception Timeout On (bt: 10ms)	0x14
S20	009E	Do not use	
S21	009F	Do not use	
S22	00A0	Do not use	
S23	00A1	Mode Miroir : Temps d'attente Trame Radio (Base de temps 10ms) Par défaut : (\$06 Maître) (\$02 Esclave)	0x06
S24	00A2	Do not use	
S25	00A3	Mirror Mode: Cycle Time (LSB) (Time base 245µs)	0x00
S26	00A4	Mirror Mode: Cycle Time (MSB)	0x08
S27	00A5	Mirror Mode: Multiplier Cycle Time	0x01
S28	00A6	Do not use	
S29	00A7	Do not use	
S30	00A8	Registry Application 5: see detail	0x05
S31	00A9	Do not use	

S32	00AA	Do not use	
S33	00AB	Do not use	
S34	00AC	Registry Application 3: see detail	0x59
S35	00AD	Registry Application 4: see detail	0x00
S36	00AE	Do not use	
S37	00AF	Do not use	
S38	00B0	Do not use	
S39	00B1	Do not use	
S40	00B2	Registry Application 6: see detail	0x60
S41	00B3	Do not use	
S42	00B4	Registry Application 7: see detail	0x00
S43	00B5	MODBUS mode: Response waiting time on RS485	0x0A
S44	00B6	Do not use	
S45	00B7	Do not use	
S46	00B8	Do not use	
S47	00B9	Mode Test : Durée De Fonctionnement du Test (LSB) (Bt :200ms) Test Mode: Test Running Time (LSB) (Bt: 200ms)	0x58
S48	00BA	Test Mode: Test Run Time (MSB)	0x02
S49	00BB	Do not use	
S50	00BC	Do not use	
S51	00BD	Do not use	
S52	00BE	Alarm: Delay allowing non-detection of the radio reception: (bt: 200ms) (LSB)	0xB0
S53	00BF	Alarm: Delay allowing non-detection radio reception (bt: 200ms) (MSB)	0x04
S54	00C0	Do not use	
S55	00C1	Do not use	
S56	00C2	Do not use	
S57	00C3	Do not use	
S58	00C4	Do not use	
S59	00C5	Do not use	
S60	00C6	Do not use	
S61	00C7	Do not use	
S62	00C8	Do not use	
S63	00C9	Do not use	
S64	00CA	Do not use	
S65	00CB	Do not use	
S66	00CC	Do not use	
S67	00CD	Do not use	
S68	00CE	Do not use	
S69	00CF	Fallback position of logic outputs	0x00
S70	00D0	Do not use	
S71	00D1	Do not use	
S72	00D2	Do not use	
S73	00D3	Do not use	

S74	00D4	Do not use	
S75	00D5	Do not use	
S76	00D6	Do not use	
S77	00D7	Do not use	
S78	00D8	Do not use	
S79	00D9	Do not use	
S80	00DA	Do not use	
S81	00DB	Do not use	
S82	00DC	Do not use	
S83	00DD	Do not use	
S84	00DE	Do not use	
S85	00DF	Do not use	
S86	00E0	Do not modify	
S87	00E1	Do not modify	
S88	00E2	Do not modify	
S89	00E3	Do not modify	
S90	00E4	Do not use	
S91	00E5	Do not use	
S92	00E6	Do not use	
S93	00E7	Do not use	
S94	00E8	Do not use	
S95	00E9	Do not use	
S96	00EA	Do not use	
S97	00EB	Do not use	
S98	00EC	Do not use	
S99	00ED	Do not use	

Application register 1: S00 (MODBUS address: 0x8A)

b0 – b3 : 0 Do not use

1. Do not use
2. ModBus mode
3. Simple master mirror mode
4. Do not use
5. Slave mirror mode
6. Slave mirror mode
7. Progamation mode
8. Do not use

b4: Do not use

b5: Do not use

b6: Do not use

b7: Do not use

Application register 2: S01 MODBUS address: 0x8B)

b0: Mirror Mode: Logic Output Enable for compatibility with older ARM-D

b1: Mirror Mode: Analog Output Input Enable for compatibility with older ARM-D

b2: Mirror Mode: Compatibility with ARMX8800 (Version> 1.20

b3: Mirror Mode: Cyclic Timeout Validation.

b4: Mirror Mode: Validation Triggering on state change of logic inputs

b5: Mirror Mode: Unidirectional Mod

b6: Mirror Mode: Compatibility with ARMX4 b7: Do not use (=0)

Application register 5: S30 (MODBUS address : 0xA8)

b0: Modbus mode: Validation reference on RS485 link

b1: Do not use (=0)

b2: Modbus mode: Cyclically controlled inputs and outputs

b3: Do not use (=0)

b4: Do not use (=0)

b5: Do not use (=0)

b6: Do not use (=0)

b7: v (=0)

Application register 3: S34 (MODBUS address 0xAC)

b0: Alarm: Validation alarm output

b1: Alarme : Autorisation Reset si 2 fois alarme

b2: Do not use (=0)

b3: Alarm: Validation Guard Dog

b4: Alarm: Validation fallback position of the outputs

b5: Do not use (=0)

b6: Alarm: Inversion of alarm output status

b7: Do not use (=0)



Application register 6: S40 (MODBUS address: 0xB2)

b0: Do not use (=0)

b1: Do not use (=0)

b2: Do not use (=0)

b3: Do not use (=0)

b4: Do not use (=0)

b5: Radio: ARM compatibility validation

b6: Radio: Validation Encoder Wheel b7: Do not use (=0)

#### Warning



Any modification of the configuration parameters causes a modification of the current program. If inconsistent data is stored, malfunctions may occur.

## 7 Troubleshooting

### The modem cannot be configured

- Check whether the power supply is correctly connected to the modem
- Check whether the green light “Power Supply” is on

### Radio data not received

- Check whether the power supply is correctly connected to the modem
- Check whether the modem has been registered on the network
- Check whether Tx and Rx lights are flashing when emission or reception

## 8 Technical support

For any information or technical problems, you can contact our technical support on this page:

<https://www.atim.com/en/technical-support/>